

APPENDIX E - FOUR-CHANNEL MEASUREMENTS WITH THE SV 06A OR SV 08A MODULES

Application

The analyser SVAN 912AE with the SV 06A and SV 08A modules can be used for four-channel sound and vibration measurements. The measurement in four channels is done simultaneously (the modules have four built-in A / D converters) in the frequency band up to 11.3 kHz. The view of the front panel of the SV 06A module is presented in Fig. E.1 and the SV 08A module – in Fig. E.2.

The SV 06A module can be used for four-channel vibration measurements. Classic piezoelectric vibration transducers (the **Charge** input) or the transducers with the built-in charge amplifier in the IEPE standard (the **Accel.** input) can be used.

The SV 08A module can be used for four-channel sound and vibration measurements. The sound measurements can be done with standard condenser microphone/preamplifier set or sound intensity probes. The transducers with the built-in charge amplifier in the IEPE standard (the **Accel.** input) can be used for the vibration measurements.

Getting started

The preparing of the SVAN 912AE instrument and the SV 06A or SV 08A modules to perform the measurements is very simple. The user has only to connect the set of preamplifiers and transducers to the inputs of the selected module, connect the SVAN 912AE with the module (SV 06A or SV 08A) using the SC 40 cable and switch on the power (independently in the instrument and in the module).



Notice: To make any interconnections between the SVAN 912AE and any other device (e.g. the measurement modules, Personal Computer or printer), **IT IS STRONGLY RECOMMENDED TO SWITCH THE POWER OFF IN ALL DEVICES.**

Each module has the input and the digital interfaces sockets (**EXT.INT** and **DIGITAL I/O**), four **OUT** sockets (placed in the bottom cover) and the **EXT. POWER** socket (placed on the side part of the module near the **EXT.INT** and **DIGITAL I/O**). These sockets are described in the Data Specification part of the Appendix E.

Powering

The SV 06A and SV 08A measurement modules are powered from the internal battery 6 V, 1.2 Ah. The external power supply unit (110 / 220 V) is added to the set, which is used to charge the internal battery by means of the **EXT. POWER** socket.



Notice: The battery is also charged during the work with the external power supply unit. The circuit for charging the battery protects it before the overcharging but it is not recommended to leave the units for a long time with the switched on power supplier.

The module can work continuously with the fully charged battery for approx. 4 hours. The weak state of the battery is signalised by the flashing diodes.

Control push-buttons of the SV 06A module

On the front panel of the SV 06A module there are the following push-buttons:

1. four <GAIN>(<INPUT>),
2. <LP. FILTER>,
3. <SHIFT>.

The meanings of the push-buttons given in the parenthesis denote the function activated after pressing the <SHIFT> push-button.

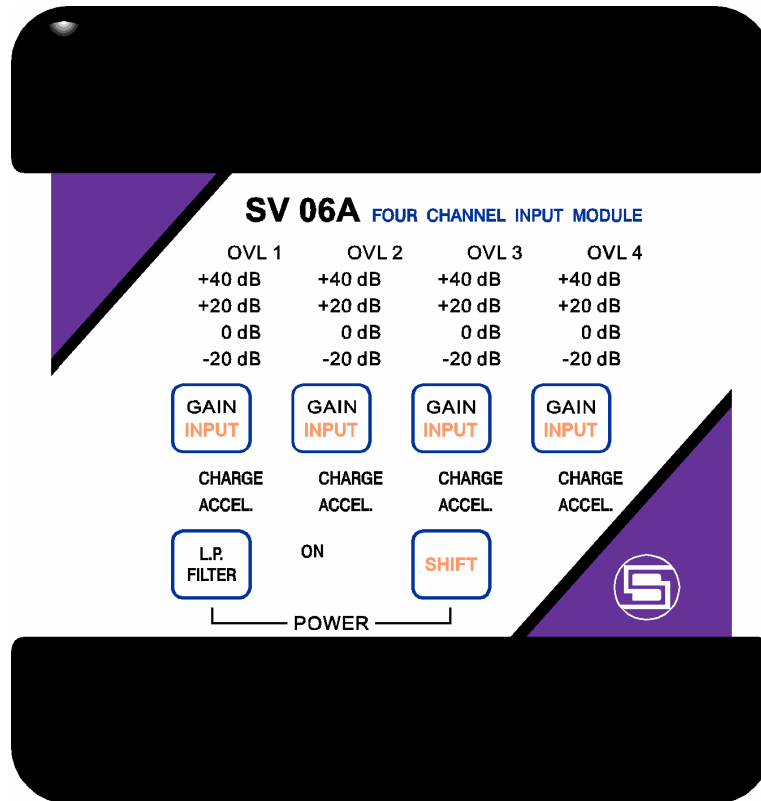

Fig. E.1. The front panel of the SV 06A four-channel module



Notice: The push-buttons of the SV 06A / SV 08A modules are active when modules are DISCONNECTED from the SVAN 912AE instrument. After connection of the SC 40 cable only the power supply can be switched on/off. All SV06/SV08 settings are then remote controlled from the SVAN 912AE. The only exception is **PLARIZATION VOLTAGE** for the SV 08A module. The proper value has to be set-up before connection of the module and analyser (**with the SC 40 cable unplugged**).

<SHIFT>

This push-button activates the additional functions of the selected control push-buttons (written in red). The <SHIFT> push-button has to be pressed immediately before the push-button which function the user has to select.

<GAIN>

This push-button sets a gain in the selected input channel. It works sequentially; each pressing causes the change of the settings in the circular way.



Notice: The current state of the input amplifier setting is signalled by the switched on LED diode placed above the <GAIN> push-button (independently for each of four channels).



Notice: The **OVERLOAD** of the input amplifier is signalled (independently for each of four channels) by the switched on the **OVL** diode placed under those denoting the measurement range.

<INPUT>

This push-button selects the type of the input for each input channel. It acts sequentially, which means that each pressing causes the circular change of the setting.



Notice: The current input type (**Charge** or **Accel.**) is signalled by the switched on LED diode placed under the **<INPUT>** push-button (independently for each of four channels).

<LP. FILTER>

This push-button switches on and off the low pass filter (cf. Data Specification).



Notice: The module is powered by simultaneous pressing the **<LP.FILTER>** and **<SHIFT>** push-buttons.

Control push-buttons of the SV 08A module

On the front panel of the SV 08A module there are the following push-buttons:

1. four **<GAIN>**(**<INPUT>**),
2. **<POLAR.VOLT.>**,
3. **<SHIFT>**.

The meanings of the push-buttons given in the parenthesis denote the function activated after pressing the **<SHIFT>** push-button.



Notice: The push-buttons of the SV 06A / SV 08A modules are active when modules are **DISCONNECTED** from the SVAN 912AE instrument. After connection of the SC 40 cable only the power supply can be switched on/off. All SV06/08 settings are then remote controlled from the SVAN 912AE. The only exception is **PLARIZATION VOLTAGE** for the SV 08A module. The proper value has to be set-up before connection of the module and analyser (**with the SC 40 cable unplugged**).

<SHIFT>

This push-button activates the additional functions of the selected control push-buttons (written in red). The **<SHIFT>** push-button has to be pressed immediately before the push-button which function the user has to select.

<GAIN>

This push-button sets a gain in the selected input channel. It works sequentially; each pressing causes the change of the settings in the circular way.



Notice: The current state of the input amplifier setting is signalled by the switched on LED diode placed above the **<GAIN>** push-button (independently for each of four channels).

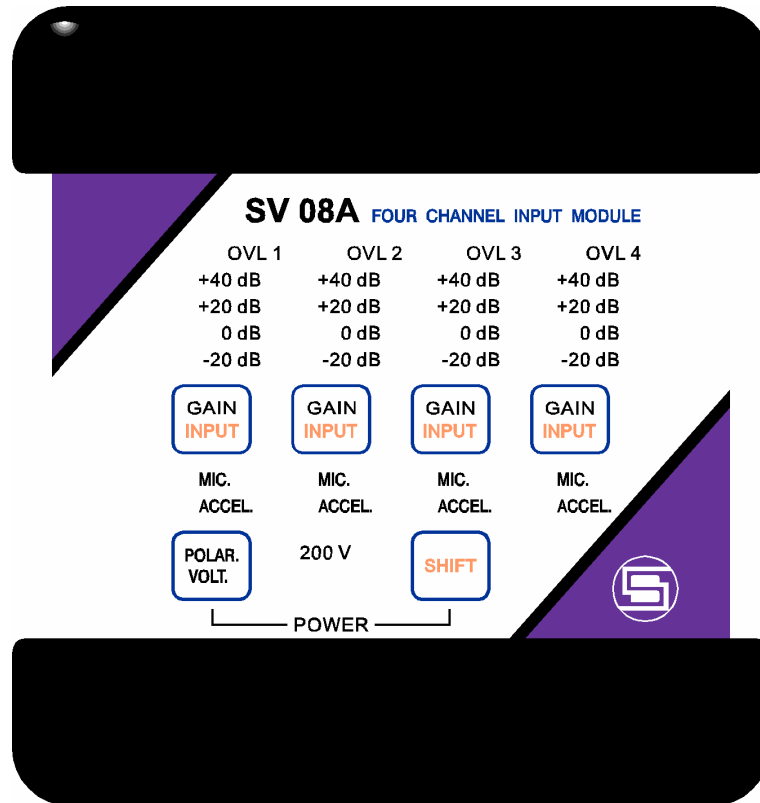

Fig. E.2. The front panel of the SV 08A four-channel module



Notice: The OVERLOAD of the input amplifier is signalled (independently for each of four channels) by the switched on the **OVL** diode placed under those denoting the measurement range.

<INPUT>

This push-button selects the type of the input for each input channel. It acts sequentially, which means that each pressing causes the circular change of the setting.



Notice: The current input type (*Mic.* or *Accel.*) is signalled by the switched on LED diode placed under the **<INPUT>** push-button (independently for each of four channels).

<POLAR.VOLT>

This push-button switches on and off the polarisation voltage for the condenser microphone (200V).



Notice: The **<POLAR.VOLT.>** push-button **must be pressed for several seconds** in order to change the polarisation voltage.



Notice: The module is powered by simultaneous pressing the **<POLAR.VOLT.>** and **<SHIFT>** push-buttons.

Selecting of the SV 06A or SV 08A module

To set the SVAN 912AE interface for the remote operation with the proper module (SV 06A or SV 08A) the user has to set **AES/EBU IN** field in the **IN/OUT SETUP** window of the **AUX. FUNCTIONS** menu.

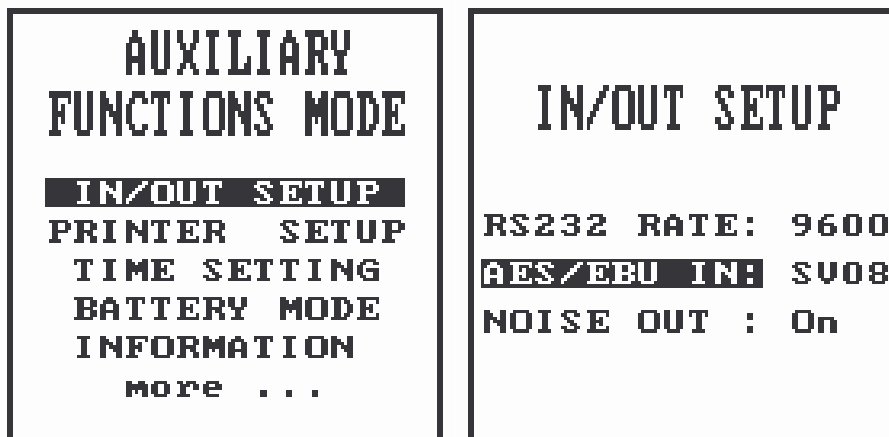

Fig. E.3. Setting of the AES/EBU IN field in the IN/OUT SETUP window of the AUX. FUNCTIONS MODE (selection of the SV 08A module)

In this window the proper module can be selected using the <◀> or <▶> push-buttons.

E1. Four channel vibration measurements with the SV 06A and SV 08A modules in the METER MODE

The vibration measurements with the SV 06A or SV 08A modules are performed similarly to one channel measurements done directly with the SVAN 912AE analyser. The main difference is fully parallel four channel measurement capability.

Measurements results presentation is extended by adding the “fifth channel”. This mode is similar to the “five profiles” display mode of the SVAN 912AE in the **METER MODE**.

In the case of the vibration measurements by the SV 06A or SV 08A modules the “fifth channel” is a Vibration Vector **V** calculated from the formula :

$$V = \sqrt{k_1^2 Y_1^2 + k_2^2 Y_2^2 + k_3^2 Y_3^2 + k_4^2 Y_4^2}$$

where:

Y_1, \dots, Y_4 – RMS results for channels 1, ..., 4;

k_1, \dots, k_4 – weighting coefficients for each channel.

Vector **V** calculation way meets requirement of the ISO 2631 standard for the Whole Body vibration measurements.

The possibilities of different measurement systems using the vibration transducers, the SV 06A / SV 08A modules and the SVAN 912AE instrument are shown in Fig. E.4.

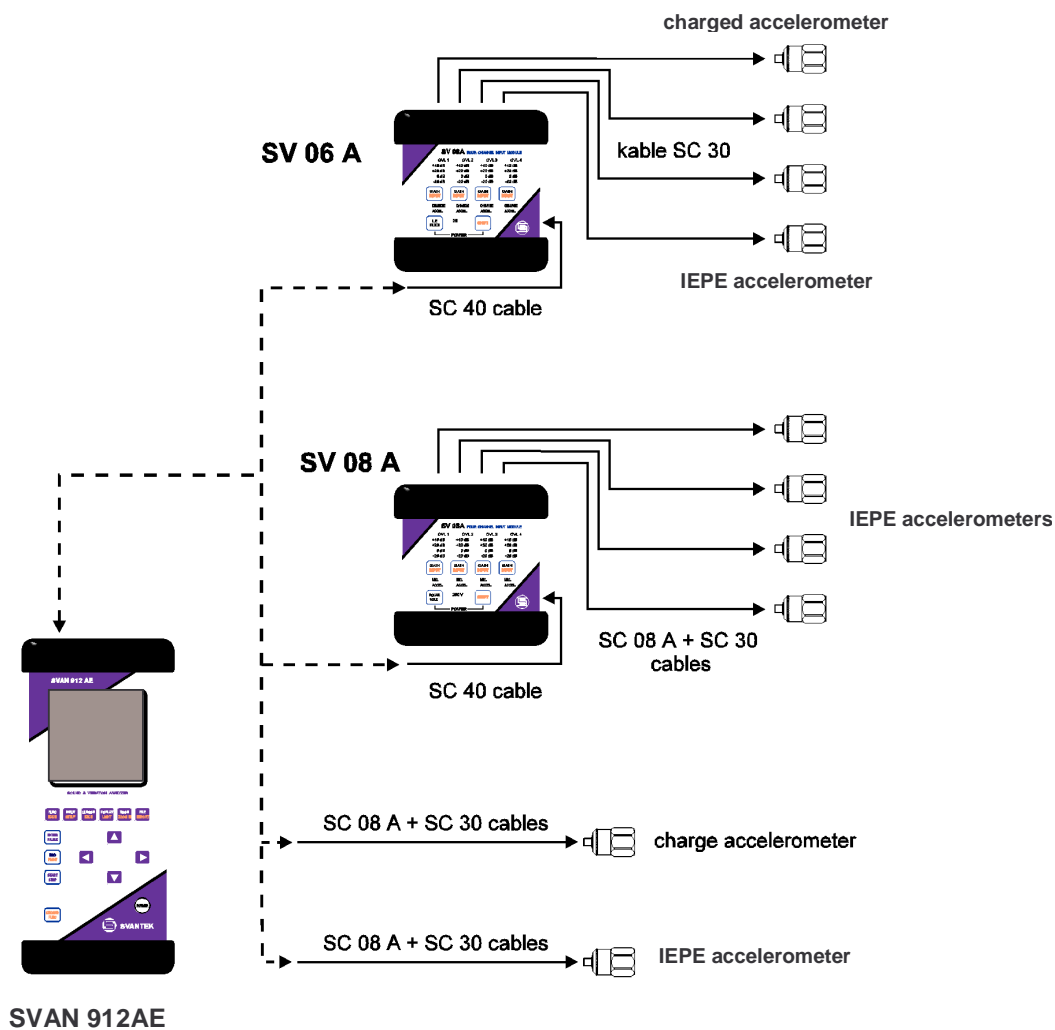

Fig. E.4. The possibilities of different measurement systems using the vibration transducers and the SVAN 912AE instrument



Notice: The particular differences in control of the SVAN 912AE analyser during four-channel measurements in comparison with one channel are presented below. It is very important to understand SVAN 912AE one-channel measurements in order to use properly this information.

The **FUNC** window

In the **METER MODE** with the SV06 or SV08 input the **Val** function is available as well as weighting filters: **HP, W-Bxy, W-Bz, H-A, W-Bc, KB, MF-Vel, Vel1, Vel3, Vel10, Dil1, Dil3** and **Dil10** (other available weighting filters are dedicated for sound measurements). Measurements of the vibration velocity and displacement is obtained by means of the selection **Vel1, Vel3, Vel10** and **Dil1, Dil3, Dil10** filters – respectively.

This sub-window enables one programming of the measurement time (**INT.TIME**) and the integration step (**ΔINTEGR.**) in the same way as for one channel operation of the SVAN 912AE instrument.



Notice: The measurement time (**INT.TIME**) and the integration step (**ΔINTEGR.**) are common for the all channels.

The **INPUT** window

This window enables the user to control remotely the SV 06A and SV 08A modules. It is possible to set independently the work conditions for each of four inputs of the measurement module (cf. Fig. E.4).

In order to start four-channel measurement (after the connection of the module according to Fig. E.4) the user has to select in the window **INPUT** the option **SV06** or **SV08** (compare **AES/EBU IN** settings).

In order to achieve it the user has to follow in the **STOP** state the steps listed below:

1. to select in the **CHANNEL** window the required number of input (measurement channel) using the **<◀>** or **<▶>** push-buttons;

| | | |
|-------------------|---|----------------------|
| 3ms ⁻² | S | INPUT |
| 1:↓ 589 | | SV06 |
| 2:↓ 785 | | CHANNEL |
| 3:↓ 562 | | 1-Charge |
| 4:↓ 2.99 | | RANGE |
| V> 1.48 | | 3.16ms ⁻² |
| 05DEC99 | | FILTER |
| | | Lin |
| | | LP_FILT. |
| | | Off |
| | | K= |
| | | 1.40 |

Fig. E.5. Four-channel measurement in METER MODE: INPUT window; INPUT:SV06

2. to set the proper input type (**Charge** or **Accel.** for the SV 06A module and **Accel.** for the SV 08A one) using the **<SHIFT>** together with **<◀>** or **<▶>** push-buttons;



Notice: When instrument is in the **RUN** mode, the channel input type cannot be changed. However, channel number can be selected. In this way the display contents will be modified without interrupting the measurement.

3. to set the required measurement range and the correcting filter (the same as in one channel work);

 **Notice:** The filters list, available with the **SV06** or **SV08** input selected, is different then in one channel mode. It includes all filters available for the Microphone & Accelerometer inputs of the SVAN 912AE: **Lin, A, C, HP, W-Bxy, W-Bz, H-A, W-Bc, KB, MF-Vel, Vel1, Vel3, Vel10, Dil1, Dil3 and Dil10.**

4. to switch on (**On**) or off (**Off**) the additional low pass filter **LP_FILTER**. (cf. Fig. E.6).

 **Notice:** This filter is only available in the SV06A module. See SV06A Technical Specification for details. It is used to attenuate the higher frequencies of the input signal (in practice - to attenuate so-called transducer resonance or noise suppression).

5. set the required values of the **K factors** (for each channel) (see Fig. E.6).

 **Notice:** The default value of the **K** is equal: $K1 = 1.40$, $K2 = 1.40$, $K3 = 1.0$, $K4 = 0$, that corresponds to the **ISO 2631** standard, when channel 1 and 2 are used for the whole body measurements with the **W-Bxy** filters and channel 3 - with the **W-Bz** filter .

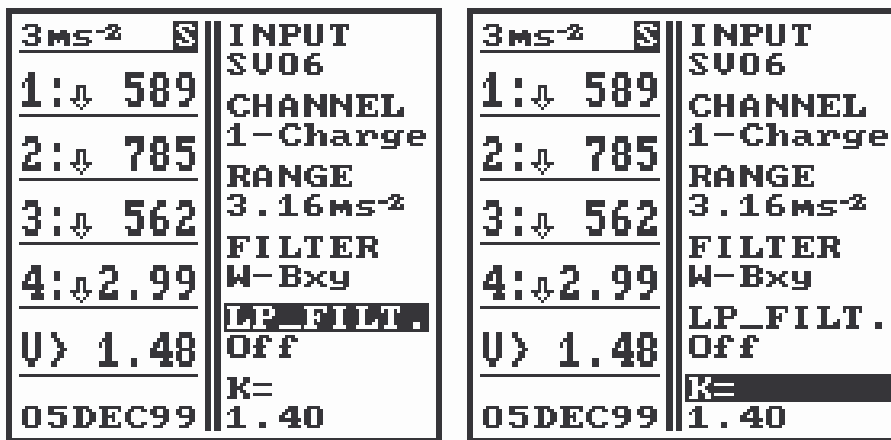

Fig. E.6. Four-channel measurement in METER MODE: INPUT window; LP_FILTER and K= fields

The DISPLAY window

This window enables the user to select one of three available measurement results presentation modes:

1-Chan., 4-Chan. and Plot.

1-Chan.

In **1-Chan.** display mode measurement results are presented in the same way as for the SVAN 912AE one channel / one profile mode (the channel number is displayed instead of the profile number)

The displayed channel number corresponds to the current setting in the **INPUT** window.

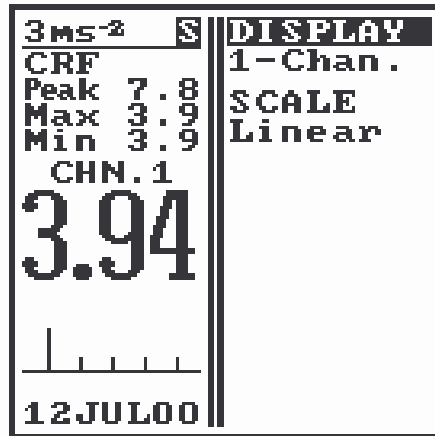



Fig. E.7. Four-channel measurement in METER MODE: DISPLAY window; DISPLAY:1-Chan.

4-Chan.

In **4-Chan.** display mode measurement results are presented in the similar way as for the SVAN 912AE one channel / five profiles mode (the **V** vector is displayed instead of the 5-th profile).



Notice: The sign '>' corresponds to the current setting in the **INPUT** window, the **CHANNEL** field and these channel results will be presented after switching to **1-Chan.** Mode.

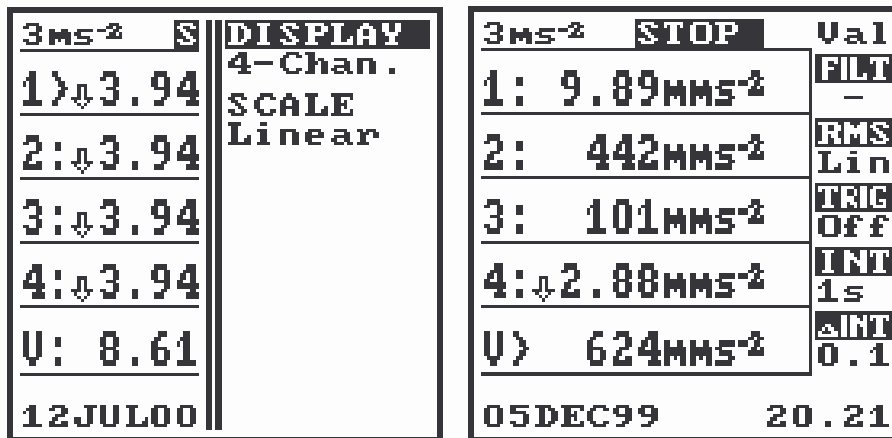



Fig. E.8. Four-channel measurement in METER MODE: DISPLAY window; DISPLAY:4-Chan.



Notice: The OVERLOAD in each channel is signalled independently by the symbol 'ø'. The OVERLOAD sign is presented when the input signal exceeds current RANGE value more than 10.7 dB. Too small input signal in a channel (UNDERRANGE) is shown using the symbol '∩' (cf. Fig. E.8). The UNDERRANGE sign is presented when input signal is less than -60.1 dB below the current RANGE value.

Plot

This mode enables one recording and displaying the time history of the measured signal. All **RMS** and / or **Peak** values are stored in the buffer with the step defined by the **ΔINTEGR.** parameter. If

DISPALY:Plot is selected, the buffer contents is presented as a time graph. The buffer can store up to 32000 results.

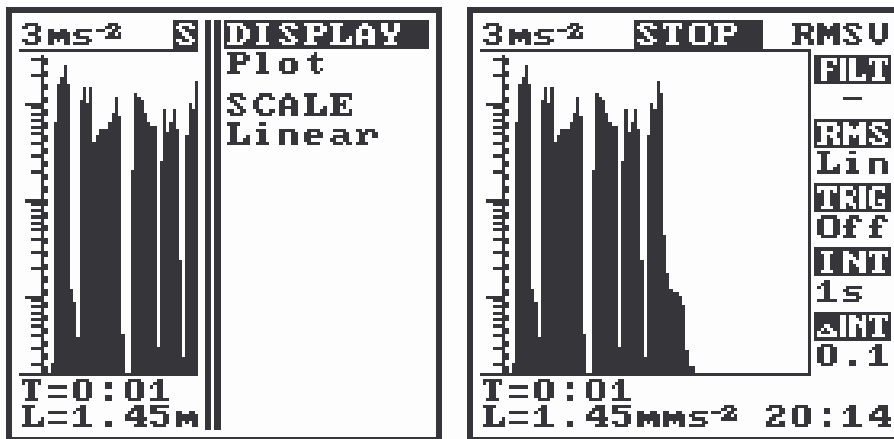

Fig. E.9. Four-channel measurement in METER MODE: DISPLAY window, Plot mode

The user can select, for each channel independently, the results stored in the buffer. Second pressing of the <DISPLAY> push-button enables one the access to the PLOT window.

For each channel the **RMS** and / or **Peak** values can be stored (including the **V** vector). So, up to ten buffers can be created.

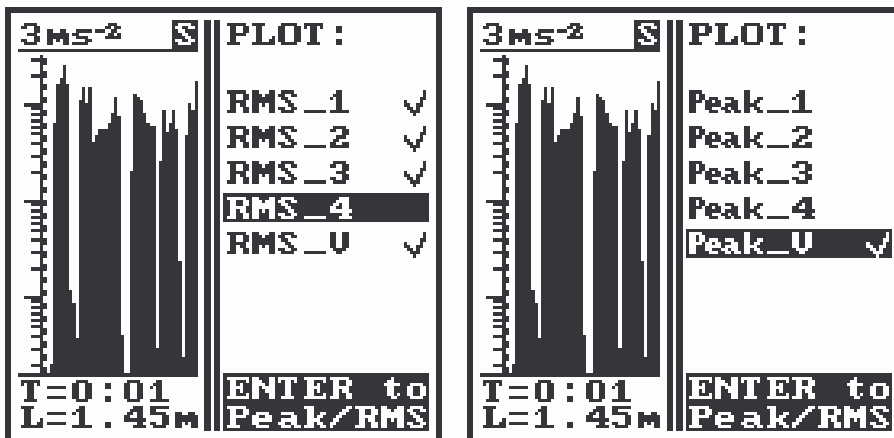

Fig. E.10. Four-channel measurement in METER MODE: DISPLAY window, Plot - buffers definition



Notice: If the number of the recorded buffers (different **RMS** and / or **Peak** results) is bigger than one. Each buffer length is equal to 32000 divided by the number of buffers.

The **PLOT** buffer contents can be:

- displayed as a time graph,
- saved as a file (by **Save** function when **DISPALY:Plot** is selected).



Notice: All buffers are stored in the same file.

E2. Four channel sound measurements with the SV 08A module in the METER MODE

The sound measurements with the SV 08A module are very similar to the vibration measurements described in the chapter E1.

Different 4-channel measurement configurations with the microphone preamplifiers and microphones (or the vibration transducers) connected to the SV 08A / SVAN 912AE system are shown in Fig. E.11.

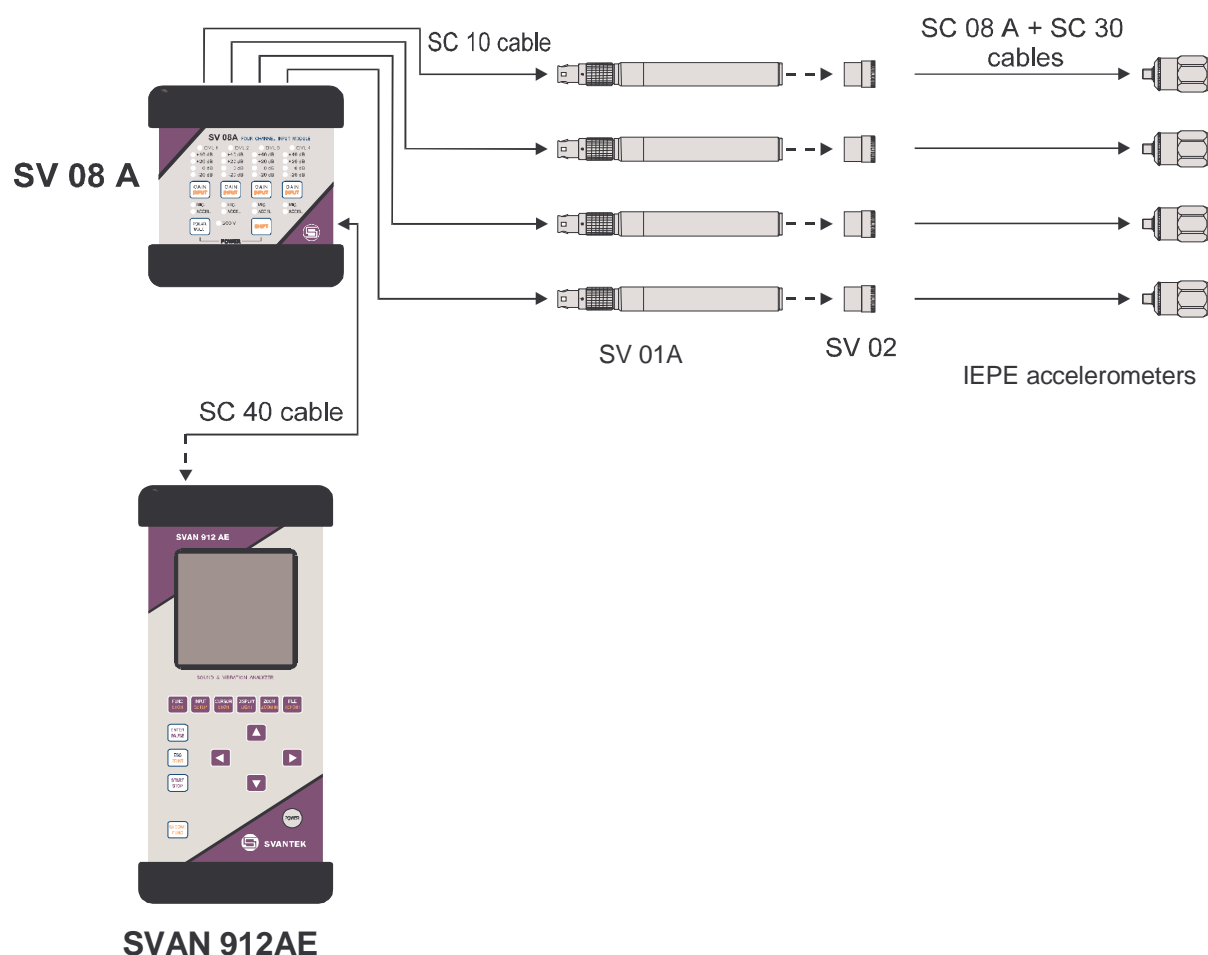

Fig. E.11. Different 4-channel measurement configurations with the microphone preamplifiers and microphones (or the vibration transducers) connected to the SVAN 912AE instrument



Notice: The particular differences in control of the SV 08A module during four-channel sound measurement in comparison with vibration measurement are presented below. The contents of the E1 part of this Appendix has to be read throughout in order to use properly this information !

In order to start four-channel measurement (after the proper connection of the module according to the Fig. E.11) the user has to set in the **INPUT** window the **SV08** option and select microphone (**Mic.**) input for each channel of the SV 08A module. See chapter E1 for details of the **INPUT** window.

| 90dB | S | INPUT |
|---------|---|----------|
| 1> | | SV08 |
| 2: | | CHANNEL |
| 3: | | 1-Mic. |
| 4: | | RANGE |
| V: | | 90dB |
| | | FILTER |
| | | Lin |
| | | LP_FILT. |
| | | Off |
| | | K= |
| 01JAN00 | | 0.00 |

Fig. E.12. Four-channel measurement in METER MODE: INPUT window; INPUT:SV08

The FUNC window

In the METER MODE with the SV08 input the **Leq** and **Sound I.** functions are available as well as weighting filters: **Lin**, **A** and **C** (other available weighting filters are dedicated for vibration measurements).



Notice: The results of the sound measurements (the **Mic.** input) are only presented in the logarithmic scale (in dB values).

| 90dB | S | FUNCTION | 90dB | E | FUNCTION |
|---------|-----|----------|---------|-----|----------|
| 1>↓ | -28 | Leq | 1: | 30 | Sound I. |
| 2:↓ | -28 | A.REPEAT | 2: | 100 | A.REPEAT |
| 3:↓ | -28 | Off | 3:↓ | 22 | On |
| 4:↓ | -28 | RMS_DET. | 4:↓ | 21 | RMS_DET. |
| V:↓ | -21 | Linear | I> | 94 | Linear |
| | | INT.TIME | | | INT.TIME |
| | | 1s | | | 1s |
| | | ΔINTEGR. | | | ΔINTEGR. |
| | | 0.1s | | | 0.1s |
| 21MAR01 | | | 16MAR01 | | PROBE |
| | | | | | 1-2/12MM |

Fig. E.13. Four-channel measurement in METER MODE: FUNC window; FUNCTION Leq or Sound I.

With the **Leq** function selected the instrument operation is similar to the **Val** function for the vibration measurements (see E.1). The **V** vector value is also calculated and displayed however it has no standard use.

The instrument operation is slightly different with the **Sound I.** function selected (see below).

Programming of the measurement time (**INT.TIME**) and the integration step (**ΔINTEGR.**) is performed in the standard way and has the same meaning for both functions.



Notice: The measurement time (**INT.TIME**) and the integration step (**ΔINTEGR.**) are common for the all channels.

When the **Sound_I.** function is selected the new parameter field, called **PROBE**, is introduced. This field is essential for the Sound Intensity measurement set-up. It includes two parameters definition:

1. Sound Intensity Probe connection to the SV08A module;
2. Sound Intensity Probe configuration (spacer length, the distance between two microphones).

| | | |
|---------|---|--------------|
| 90dB | E | FUNCTION |
| 1: 30 | | Sound I. |
| 2: 100 | | A.REPEAT |
| 3:↓ 22 | | On |
| 4:↓ 21 | | RMS_DET. |
| I> 88 | | Linear |
| 16MAR01 | | INT.TIME |
| | | 1s |
| | | ΔINTEGR. |
| | | 0.1s |
| | | PROBE |
| | | 1-2/50mm |

| | | |
|---------|---|--------------|
| 90dB | E | FUNCTION |
| 1: 30 | | Sound I. |
| 2: 100 | | A.REPEAT |
| 3:↓ 22 | | On |
| 4:↓ 22 | | RMS_DET. |
| I>↓ -19 | | Linear |
| 16MAR01 | | INT.TIME |
| | | 1s |
| | | ΔINTEGR. |
| | | 0.1s |
| | | PROBE |
| | | 1-4/50mm |

Fig. E.14. Four-channel measurement in METER MODE: the FUNCTION window, the Sound I. function, the PROBE field definition

Sound Intensity Probe connection is denoted by the pairs of the SV 08A input channel numbers. It corresponds to the physical Intensity Probe connection with SV 08A module. All combinations of the input pairs are possible and can be selected by means of the <◀> and <▶> push-buttons. The default setting is 1-2. **It is assumed that A channel of the probe is connected to the input 1 and B channel is connected to the channel 2!**



Notice: The connection of the Sound Intensity Probe has a direct relation with the measured **Sound Intensity direction** which is signalled by the space character or '-' one appearing before the result of the measurement. Space character means that the direction of the sound intensity vector is in the accordance with the settings of the microphone pair A-B connected to the inputs 1-2 of the SV 08A module.

Sound Intensity Probe spacer length (it means the distance between both microphones of the probe) can be selected from the following list:

6 mm, 8 mm, 12 mm, 25 mm, 50 mm and 10 cm.

It can be done by means of the <SHIFT> together with the <◀> or <▶> pushbuttons.



Notice: The selection of the proper value of the Sound Intensity Probe spacer (the distance between two microphones of the probe) has a direct relation with the measured **Sound Intensity value!**

The presentation of the Sound Intensity measurement results is given in all three display modes described in chapter E.1 (1-Chan., 4-Chan. and Plot).

In 1-Chan. display mode the measured **Sound Intensity** value (**S.I.**) is displayed in a standard way, together with **Peak**, **Max** and **Min** values. Sound Intensity direction is denoted by the character '-' before the **S.I.** result (if reversed to the input configuration).

If warning **UNDER** appears above the **S.I.** result it denotes situation when at least one of the input signals from the intensity probe is too low (UNDERRANGE).

In **4-Chan.** display mode the measured **Sound Intensity** value (**S.I.**) is displayed in the **V** vector field (cf. E.1). Additionally, the measured **RMS** values from all input channels are displayed in parallel.

The underrange and overload conditions are pointed by the arrows down and up independently for all channels.

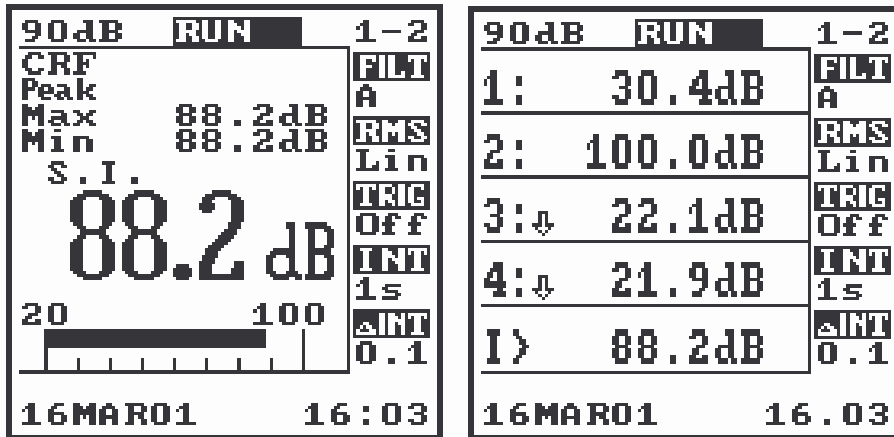

Fig. E.15. Four-channel measurement in METER MODE: the Sound_I function, 1-Chan. and 4-Chan. display mode

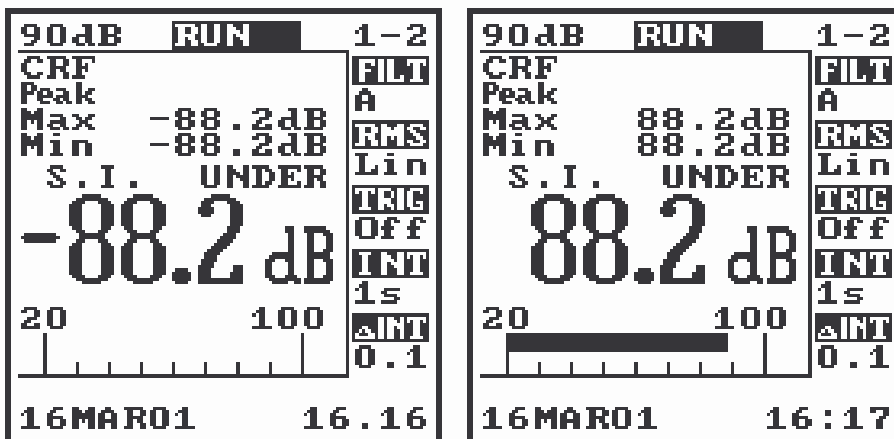

Fig. E.16. Four-channel measurement in METER MODE: the Sound_I function, the S.I. vector direction and UNDERRANGE input

In the **Plot** display mode only **RMS Sound Intensity** value (**S.I.**) can be recorded and displayed.

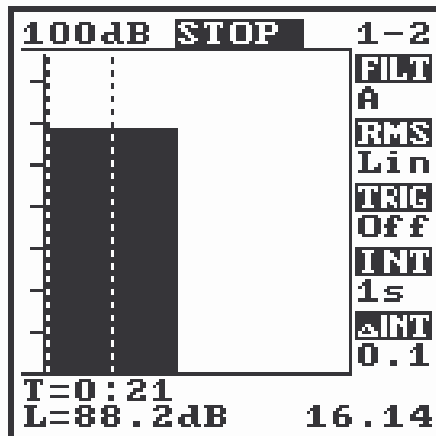

Fig. E.17. Four-channel measurement in METER MODE: the Sound_I function, S.I. Plot display mode

E3. Four channel sound & vibration measurements with the SV 06A and SV 08A modules in the ANALYZER MODE

In the **ANALYZER MODE** two functions are available: **Time** (time waveform of the acceleration of vibrations) and **Spectrum** (power spectrum for acceleration, velocity and displacement of vibrations). The **LP_FILT.** filter is accessible only for the SV 06A module (cf. Data Specification).

In order to start four-channel measurement (after the connection of the module according to Fig. E.1) the user has to set in the **INPUT** sub-window of the **INPUT** window the **SV06** or **SV08** option (similarly as in the **METER MODE** - cf. Fig. E.18).

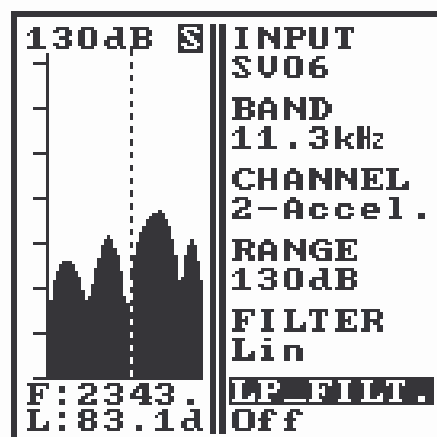

Fig. E.18. Four-channel measurement in ANALYZER MODE: INPUT window; LP_FILT:Off, FUNCTION: Spectrum

The measurement results from one channel (currently selected in the **INPUT** sub-window) are displayed in the same way as in the case of one channel work.

The **INPUT** window enables the user to control remotely the SV 06A and SV 08A modules. It is possible to set independently the work conditions for each of four inputs of the measurement module.

In order to achieve it the user has to follow, in the **STOP** state, the steps listed below:

1. to select in the **CHANNEL** window the required number of input (measurement channel) using the <◀> or <▶> push-buttons;
2. to set the proper input type (**Charge** or **Accel.**) using the <SHIFT> together with <◀> or <▶> push-buttons;
3. to set the required measurement range;



Notice: Only **Lin** filter can be used in this mode.

4. to switch on (**On**) or off (**Off**) the additional low pass filter **LP_FILT.** (cf. Fig. E.18).



Notice: This filter is available only in the SV 06A module (cf. Data Specification of SV 06A). It is used to attenuate the higher frequencies of the input signal (in practice - to attenuate so-called transducer resonance or noise suppression).



Notice: In the **RUN** mode it is **not possible** to change the input type. However using the <SHIFT>/<◀> or <SHIFT>/<▶> push-buttons it is possible to change the input number in this mode.



Notice: For four-channel measurements nine frequency bands with upper frequency from 44.2 Hz to 11.3 kHz are available (cf. Fig. E.19). The lower measurement frequency (-3 dB) is the function of the measurement range and changes from 2 Hz for 11.3 kHz band to 0.2 Hz for 1.41 kHz band and all lower!

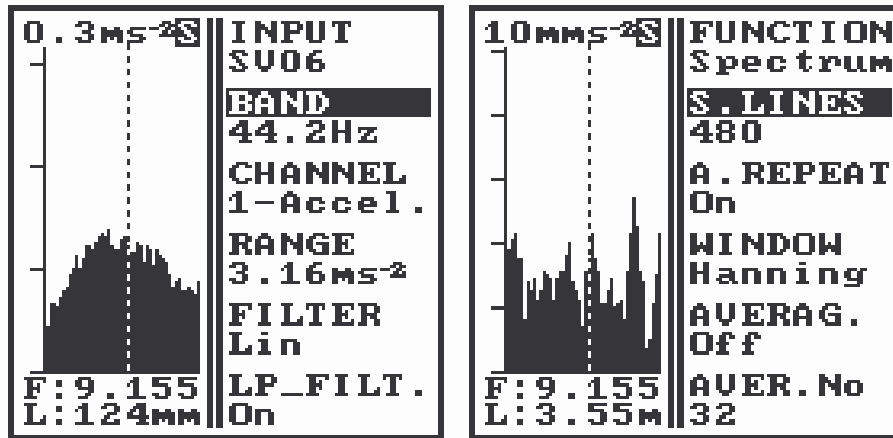

Fig. E.19. Four-channel measurement in ANALYZER MODE: INPUT window, BAND:44.2 Hz and FUNC window, S.LINES: 480 (FUNCTION: Spectrum)



Notice: The ZOOM function is not available for four-channel measurements. Maximal number of FFT spectrum lines is limited to 480 (cf. Fig. E.19).

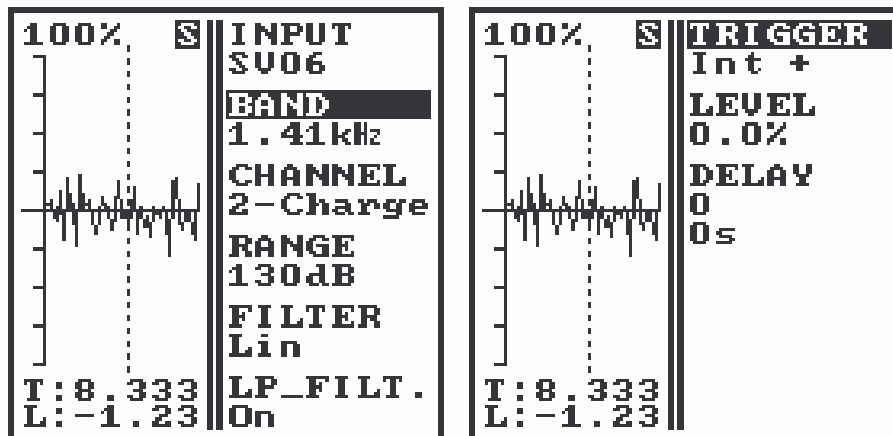

Fig. E.20. Four-channel measurement in ANALYZER MODE: INPUT window, BAND: 1.41 kHz and TRIGGER window, TRIGGER: Int+ (FUNCTION: Time)



Notice: For four-channel measurements TRIGGER function (cf. Fig. E.20) is available only for channel No 1.

E4. Storing measurement results

The results of four-channel measurements can be stored in the same way as for one channel work.



Notice: *The results of four-channel measurements are stored simultaneously for all four channels independently from the current setting in the **INPUT** window.*

The formats of the files containing the results of four-channel analysis are presented in App. B.

E5. Calibration

The calibration of four-channel system is performed as for one-channel measurements. The calibration procedure described in Chapter 6 should be repeated one after another for all four channels of the SV 06A or SV 08A module. The selection of the currently calibrated input is done in the same way as it was described earlier - by the proper option chosen in the **INPUT** window (with the contents the same as in the **METER MODE**).

All calibration coefficients (factors) can be stored in a corresponding SETUP file and restored after its reading similarly as during one channel measurements.

E6. Data specifications of the SV 06A module

Number of channels 4.

Charge input (each channel):

Socket: BNC.
Impedance: 220 Ω / 255 pF.
Time constant of integration circuit: 4.6 s.
Measurement ranges: 4 sub-ranges: 3.16 pC, 31.6 pC, 316 pC, 3.16 nC (20 dB step).
Values of measured charge: 25 fC_{RMS} ÷ 10.2 nC_{RMS} (for the **Lin** filter).
Low Pass filter (**LP_FILT.**): for 1 kHz the attenuation is smaller or equal to -0.2 dB, for 15.0 kHz the attenuation is greater or equal to -30 dB) with -12 dB / octave slope, selected by the user.
Lin filter: 16 Hz / -0.1 dB (1.85 Hz / -3 dB) with 6 dB / octave slope.

Acceleration input (each channel):

Socket: BNC.
Impedance: 100 k Ω / 200 pF.
Powering of vibration transducer: current source 28 V / 4 mA.
Measurement ranges: 4 sub-ranges: 3.16 mV, 31.6 mV, 316 mV, 3.16 V (20 dB step).
Input voltage: 3.16 μ V_{RMS} ÷ 10.2 V_{RMS} (10 dB ÷ 140.2 dB; related to 1 μ V_{RMS}).
Lin filter: 5.00 Hz – 11.93 kHz (-3 dB) with 18 dB/octave slope.
HP filter: 0.625 Hz – 11.93 kHz (-3 dB) with 18 dB/octave slope.

Internal noise level:

Wide-band noise level measured for the short cut **Accel.** input (11.3 kHz band):

- with the **Lin** filter < 20 μ V_{RMS}.

Noise level in the **Charge** channel measured for the substitute capacity of the transducer equal to 1 nF:

- with the **Lin** filter < 10 f C.

Maximal input voltage:

The SV 06A module is the instrument of the 2nd class of safety (IEC 348 standard). Maximal voltage between the signal source ground and the earth can not exceed 42 V_{PEAK} or has to have the current productivity limited to 0.7 mA of peak value.

Maximal peak voltage: 200 V of peak value or 50 V of constant voltage for the **Accel.** input.

Overload detection:

The module has built-in overload detectors. The overload in the analogue part of the measurement channel as well as in the analogue/digital converter are both detected.

Antialiasing filters:

Pass band (- 3 dB): 1.85 Hz - 11.880 kHz,
or : 0.9 Hz - 5.940 kHz.
Stop band: from 6.25 kHz or from 12.5 kHz.
Attenuation in the stop band: > 80 dB.

Sampling frequency: internal: 24 kHz.

Analogue/digital conversion: 18 bits.

Total linearity error:

- from 0 to 70 dB below the maximal value on the selected range < 0.5 dB
(with the exception for the lowest ranges where the dynamics is limited by the noise).

Reference range: 150 dB.

Basic measurement error: < ± 0.2 dB in the temperature $T=+23^{\circ}\text{C} \pm 5^{\circ}\text{C}$ for sinusoidal signal.

Measurement error in the full temperature range:

< ± 0.3 dB in the temperature range from -10°C to $+50^{\circ}\text{C}$ for the sinusoidal signal.

Accuracy of input dividers: ± 0.1 dB.



Notice: For the analogue outputs (Analogue Signal Output) the accuracy of the input dividers is equal to ± 1.5 dB.

Stability of the amplitude measurement: ± 0.1 dB.

Accuracy and stability of the internal frequency source: 0.01 %.

Analogue outputs (each channel): 4.

Signal Out (Analogue Signal Output) standardised output voltage for channels 1-4 is equal to $282\text{ mV}_{\text{RMS}}$.

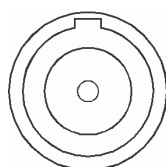

LEMO compatible, type ERN.00.250 socket (view from outside).

| Pin number | ERN.00.250 |
|------------|------------|
| 1 | output |
| shield | ground |

Socket: one contact LEMO compatible type ERN.00.250.
Voltage level: $282\text{ mV}_{\text{RMS}} (\pm 15\%)$ for the input sinusoidal signal conforming to the nominal range value. The frequency band of the signals on **AC OUT** (-3 dB) is equal to 0.12 Hz – 150 kHz, (-0.1 dB: 1 Hz – 30 kHz)
Input type: single end with the output impedance $51\ \Omega / 1\%$.

Digital data Input / Output:

Socket: seven-pin LEMO compatible type ENG.1B.307 socket.

Interface standard: AES/EBU, IEC 958, S/PDIF, EIAJ CP-340.
 Receiver type: balanced with the impedance equal to $110 \Omega / \pm 20\%$.

The figure presenting seven pin digital Input / Output socket of the module together with the description of their pins is given below.

| | |
|-------------|------------------------------|
| Pin number | ENG.1B.307 |
| 1 - EXT.PGM | CMOS input |
| 2 - SV912 | CMOS input |
| 3 - unused | |
| 4 - TXP | output - positive phase |
| 5 - TXN | output - negative phase |
| 6 - EXT ACC | powering from the SVAN 912AE |
| 7 - GND | ground |

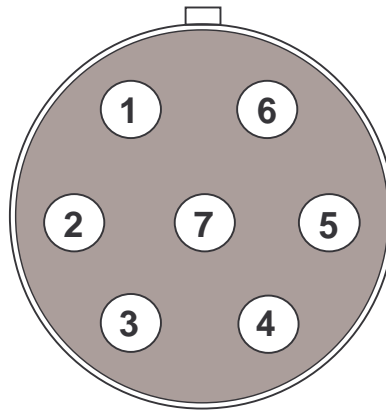

LEMO compatible type ENG.1B.307 socket (view from outside)

Triggering input EXT. INT.

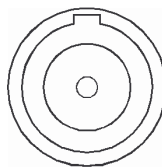

LEMO compatible type ERN.00.250 socket (view from outside).

| | |
|------------|------------|
| Pin number | ERN.00.250 |
| 1 | input |
| shield | ground |

This input is used for external triggering or synchronising signals with the level of $+5 V / 10 mA$, with the active arising slope of the impulse.

Powering:

The SV 06A module can be powered from the external source (battery or alternating current power supplier) with the constant voltage level of 12 V. The noise and distortion should not exceed $\pm 5\%$. Current productivity: - 12 V / 1000 mA DC.

The powering from the internal battery is the basic working mode of the module.

The SV 06A module contains the internal 6 V / 1.2 Ah battery and built-in circuit for charging it (in order to charge properly the powering circuits cf. Chapter 7).

Totally uncharged battery has to be powered about 14 h in order to achieve the state of being fully charged (for non-damaged battery).

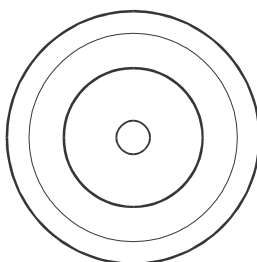

SWITCHCRAFT compatible connector type 722A 5.0 mm / 2.1 mm (external view)

| | |
|------------|--------------|
| Pin number | 722A 5.0/2.1 |
| shield | ground |
| 1 | + 12 V |

Mass (together with battery): 1.1 kg.

Dimensions:

- Height 126 mm,
- Width 114 mm,
- Depth 69 mm.

Electromagnetic resistance:

Electromagnetic field with the density of 80 A / m increases the internal noise level not more than 10 dB.

Environmental parameters:

- Range of temperature for work: from -10°C to $+50^{\circ}\text{C}$.
- Range of temperature for stocking: from -20°C to $+50^{\circ}\text{C}$.
- Humidity: 90 % RH in 30°C (non-condensed vapour).

SV 06 A

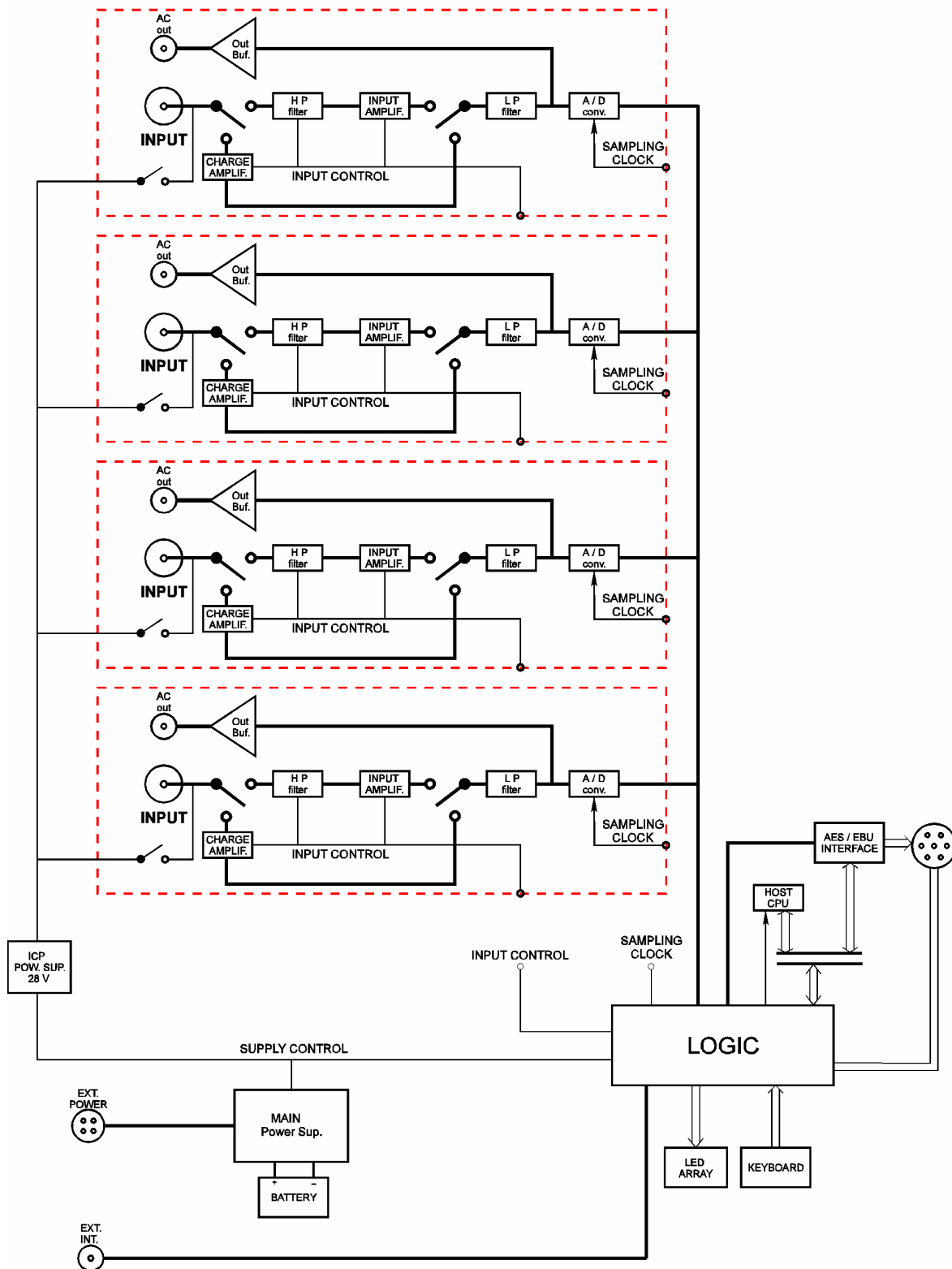

Fig. E.21. Block diagram of the SV 06A module

E7. Data specifications of the SV 08A module

Number of channels 4.

Microphone input:

Connector: 7-pin LEMO compatible connector type ENG.1B.307.
 Impedance: 1 M Ω / 40 pF.
 Measurement range: 4 ranges with the nominal values: 3.16 mV, 31.6 mV, 316 mV, 3.16 V (20 dB step).
 Input voltage range: 3.16 μ V_{RMS} ÷ 10.2 V_{RMS} (10 dB ÷ 140.2 dB related to 1 μ V_{RMS}).
 Microphone polarisation: 0 V or 200 V.
 Microphone preamplifier powering: 28 V.

Filters:

Lin filter: 5.00 Hz – 11.93 kHz (-3 dB) with 18 dB/octave slope.
A filter: Type 1 according to the IEC 651 standard.
C filter: Type 1 according to the IEC 651 standard.

Accelerometer input:

Connector: BNC with SC 08 cable (7-pin LEMO compatible connector type ENG.1B.307 to BNC).
 Impedance: 1 M Ω / 75 pF (with the SC 08 cable).
 Vibration transducer powering: 28 V / 4 mA current source.
 Measurement range: 4 ranges with the nominal values: 3.16 mV, 31.6 mV, 316 mV, 3.16 V (20 dB step).
 Range of the measured voltage: 35.5 μ V_{RMS} ÷ 10.2 V_{RMS} (10 dB ÷ 140.2 dB related to 1 μ V_{RMS}).
Lin filter: 5.00 Hz – 11.93 kHz (-3 dB) with 18 dB/octave slope.
HP filter: 0.625 Hz – 11.93 kHz (-3 dB) with 18 dB/octave slope.

Below, the SV 08A 7-pin LEMO compatible input connector pin-out is given. Some other condenser microphone preamplifiers available on the market, are also presented.

| | SV08A (female) | SVANTEK SV01A | G.R.A.S. 26AB | NORSONIC 1201 | B&K 2669 |
|--------|-------------------|------------------|---------------|---------------------|------------------------|
| 1 | NC | - | - | heater 225 Ω | calibration |
| 2 | signal ground | ground | signal ground | signal ground | signal ground |
| 3 | 200 V | 200 V | 200 V | 200 V | 200 V |
| 4 | input | output | output | output | output |
| 5 | NC | - | - | 28 V | - |
| 6 | +28 V | +28 V | 120 V | 120 V | 28 V ÷ 120 V |
| 7 | supply ground | supply ground | supply ground | supply ground | ground (neg. supp.) |
| Shield | signal ground | signal ground | ? | ? | chassis |

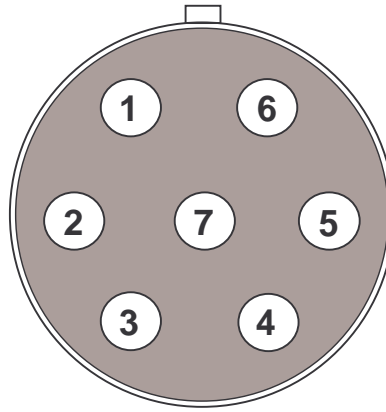

LEMO compatible connector type ENG.1B.307 (view from outside)

Internal noise level:

Wideband noise level measured with the voltage input short-circuit (22.6 kHz band):

- with **LIN** filter: $< 1.8 \mu\text{V}_{\text{RMS}}$,
- with **A** filter: $< 1.5 \mu\text{V}_{\text{RMS}}$,
- with **C** filter: $< 1.1 \mu\text{V}_{\text{RMS}}$.

Maximal input voltage:

The SV 08A module is the instrument of the II class of safety (IEC 348). Maximal voltage between the signal source ground and the earth can not exceed $42 V_{\text{PEAK}}$ or has to have the current productivity limited to 0.7 mA of peak value.

Maximal peak voltage: 200 V of peak value or 50 V of constant voltage for the **Accel.** input.

Overload detection:

The module has built-in overload detectors. The overload in the analogue part of the measurement channel as well as in the analogue/digital converter are both detected.

Antialiasing filters:

Pass band (- 3 dB): 1.85 Hz - 11.880 kHz,
or : 0.90 Hz - 5.940 kHz.

Stop band: from 6.25 kHz or from 12.5 kHz.

Attenuation in the stop band: > 80 dB.

Sampling frequency: internal: 24 kHz.

Analogue/digital conversion: 18 bits.

Total linearity error:

- from 0 to 80 dB below the maximal value on the selected range < 0.5 dB
(with the exception for the lowest ranges where the dynamics is limited by the noise).

Reference range: 150 dB for **INPUT: Accel.**
110 dB for **INPUT: Mic.**

Basic measurement error: $< \pm 0.2$ dB in the temperature $T=+23^{\circ}\text{C} \pm 5^{\circ}\text{C}$ for sinusoidal signal.

Measurement error in the full temperature range:

$< \pm 0.3$ dB in the temperature range from -10°C to $+50^{\circ}\text{C}$ for the sinusoidal signal 1kHz.

Accuracy of input dividers: ± 0.1 dB.



Notice: For the analogue outputs (Analogue Signal Output) the accuracy of the input dividers is equal to ± 1.5 dB.

Stability of the amplitude measurement: ± 0.1 dB.

Accuracy and stability of the internal frequency source: 0.01 %.

Analogue outputs (each channel): 4.

Signal Out (Analogue Signal Output) standardised output voltage for channels 1 - 4 is equal to $282 \text{ mV}_{\text{RMS}}$.

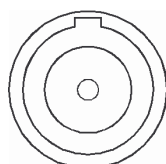

LEMO compatible type ERN.00.250 socket (view from outside).

| | |
|------------|------------|
| Pin number | ERN.00.250 |
| 1 | output |
| shield | ground |

Socket: one contact LEMO compatible type ERN.00.250.

Voltage level: $282 \text{ mV}_{\text{RMS}} (\pm 15 \%)$ for the input sinusoidal signal conforming to the nominal range value. The frequency band of the signals on **AC OUT** (-3 dB) is equal to $0.12 \text{ Hz} - 150 \text{ kHz}$, (-0.1 dB: $1 \text{ Hz} - 30 \text{ kHz}$)

Input type: single end with the output impedance $51 \Omega / 1 \%$.

Digital data Input / Output:

Socket: seven-pin LEMO compatible type ENG.1B.307 socket.

Interface standard: AES/EBU, IEC 958, S/PDIF, EIAJ CP-340.

Receiver type: balanced with the impedance $110 \Omega / \pm 20 \%$.

The figure presenting seven pin digital Input / Output socket of the module together with the description of its pins is given below.

| | |
|-------------|------------------------------|
| Pin number | ENG.1B.307 |
| 1 - EXT.PGM | CMOS input |
| 2 - SV912 | CMOS input |
| 3 - unused | |
| 4 - TXP | output - positive phase |
| 5 - TXN | output - negative phase |
| 6 - EXT ACC | powering from the SVAN 912AE |
| 7 - GND | ground |

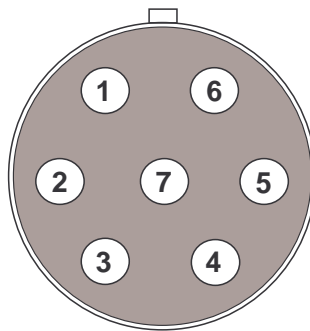

LEMO compatible type ENG.1B.307 socket (view from outside)

Triggering input EXT. INT.

This input is used for external triggering or synchronising signals with the level of +5 V / 10 mA, with the active arising slope of the impulse.

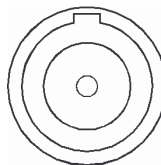

LEMO compatible type ERN.00.250 socket (view from outside)

| | |
|------------|------------|
| Pin number | ERN.00.250 |
| 1 | input |
| shield | ground |

Powering:

The SV 08A module can be powered from the external source (battery or alternating current power supplier) with the constant voltage level of 12 V. The noise and distortion should not exceed $\pm 5\%$. Current productivity: - 12 V / 1000 mA DC.

The powering from the internal battery is the basic working mode of the module.

The SV 08A contains the internal 6 V / 1.2 Ah battery and built-in circuit for charging it (in order to charge properly the powering circuits cf. Chapter 7).

Totally uncharged battery has to be powered about 14 h in order to achieve the state of being fully charged (for non-damaged battery).

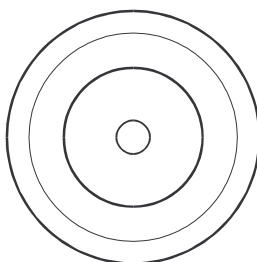

SWITCHCRAFT compatible connector type 722A 5.0 mm / 2.1 mm (external view)

| | |
|------------|--------------|
| Pin number | 722A 5.0/2.1 |
| shield | ground |
| 1 | + 12 V |

Mass (together with battery): 1.1 kg.

Dimensions:

- Height 126 mm,
- Width 114 mm,
- Depth 69 mm.

Electromagnetic resistance:

Electromagnetic field with the intensity of 80 A / m increases the internal noise level not more than 10 dB.

Environmental parameters:

- Range of temperature for work: from -10°C to $+50^{\circ}\text{C}$.
- Range of temperature for stocking: from -20°C to $+50^{\circ}\text{C}$.
- Humidity: 90 % RH in 30°C (non-condensed).

SV 08 A

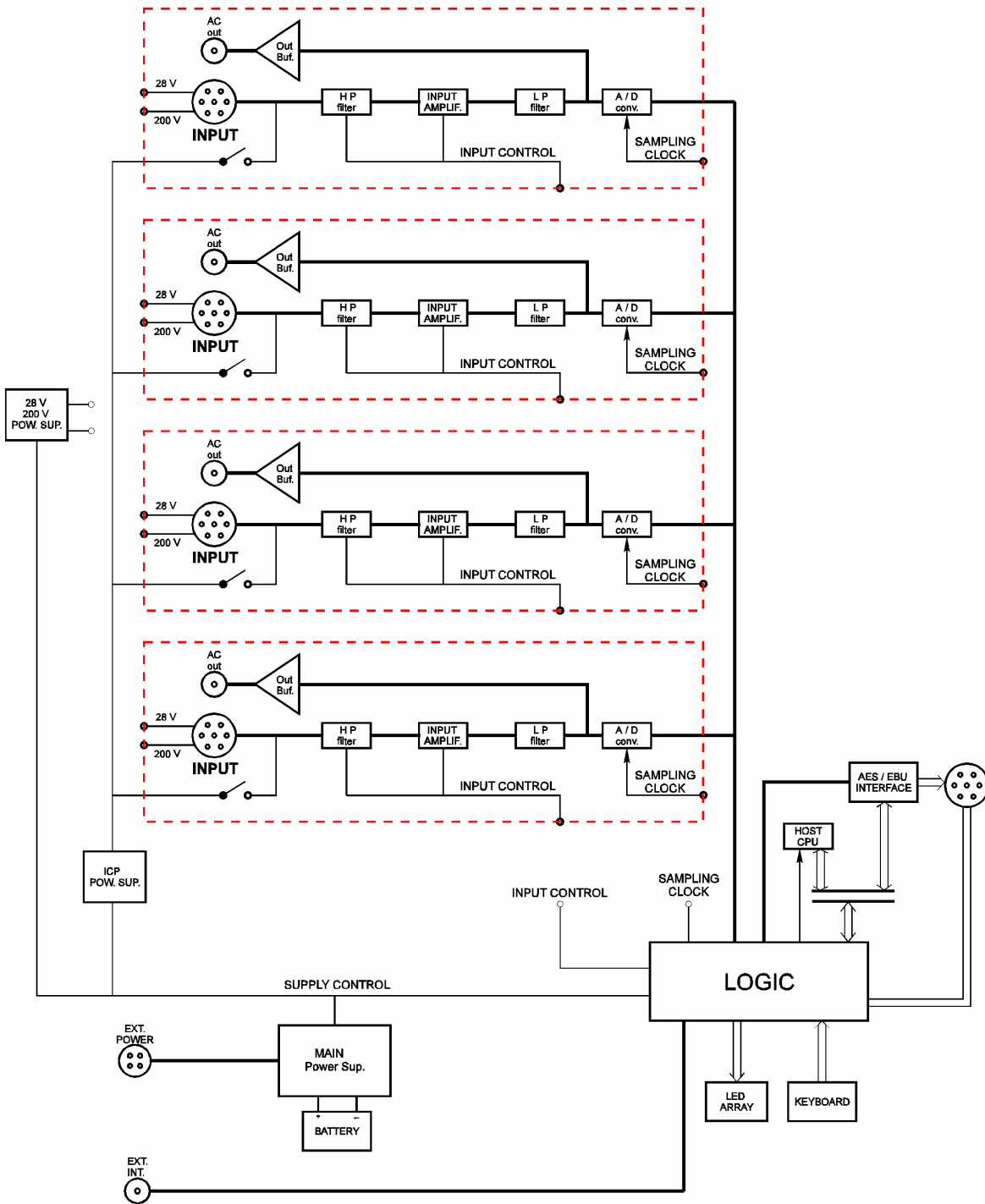

Fig. E.22. Block diagram of the SV 08A module

E8. System for vibration measurements with the SV 06A module

System conforms to the ISO 8041 standard for the general vibration measurements and for human response to the mechanical vibration meeting requirements for Type 1 Meter.

System configuration:

- Handheld sound & vibration analyser SVAN 912AE
- The SV 06A module
- Measurement IEPE transducer with the sensitivity from 0.01 mV/ms⁻² to 1500 mV/ms⁻²
or
- Measurement charged transducer with the sensitivity from 0.01 pC/ms⁻² to 1500 pC/ms⁻²

Measurements of the vibration's acceleration

Measurement ranges for the acceleration (for the transducer with the sensitivity equal to 10 mV/ms⁻² or 10 pC/ms⁻²):

4 ranges with the nominal values: 316 mms⁻², 3.16 ms⁻², 31.6 ms⁻², 316 ms⁻²
(110 dB, 130 dB, 150 dB, 170 dB related to 10⁻⁶ ms⁻²).

Values of the measured acceleration (for the transducer with the sensitivity equal to 10 mV/ms⁻² or 10 pC/ms⁻²):

- linear measurement (with the **HP** or **Lin** filter)

INPUT: Accel.

the measurement ranges for the distance from noise > 5 dB:
from 0.004 ms⁻² to 1000 ms⁻² (the sinusoidal signal RMS)
from 0.02 ms⁻² to 1410 ms⁻² (PEAK)

the measurement range (PEAK) with the measurement error < ± 0.5 dB:
from 0.2 ms⁻² to 1410 ms⁻².

| RANGE (RMS) | Range of measurements | |
|--------------------------------|-----------------------------|--------------------------|
| 316 mms ⁻² (110 dB) | from 0.004 ms ⁻² | to 1 ms ⁻² |
| 3.16 ms ⁻² (130 dB) | from 0.004 ms ⁻² | to 10 ms ⁻² |
| 31.6 ms ⁻² (150 dB) | from 0.01 ms ⁻² | to 100 ms ⁻² |
| 316 ms ⁻² (170 dB) | from 0.1 ms ⁻² | to 1000 ms ⁻² |

INPUT: Charge

the measurement ranges for the distance from noise > 5 dB:
from 0.003 ms⁻² to 1000 ms⁻² (the sinusoidal signal RMS)
from 0.007 ms⁻² to 1410 ms⁻² (PEAK)

the measurement range (PEAK) with the measurement error < ± 0.5 dB:
from 0.1 ms⁻² to 1410 ms⁻².

| RANGE (RMS) | Range of measurements | |
|--------------------------------|-----------------------------|------------------------|
| 316 mms ⁻² (110 dB) | from 0.003 ms ⁻² | to 1 ms ⁻² |
| 3.16 ms ⁻² (130 dB) | from 0.003 ms ⁻² | to 10 ms ⁻² |

| | | |
|--------------------------------|----------------------------|--------------------------|
| 31.6 ms ⁻² (150 dB) | from 0.01 ms ⁻² | to 100 ms ⁻² |
| 316 ms ⁻² (170 dB) | from 0.1 ms ⁻² | to 1000 ms ⁻² |

- corrected measurement (with the **W-Bxy**, **W-Bz**, **W-Bc**, **H-A** or **KB** filter)

INPUT: Accel.

the measurement ranges for the distance from noise > 5 dB:

from 0,0005 ms⁻² to 1000 ms⁻² (the sinusoidal signal RMS)

from 0.002 ms⁻² to 1410 ms⁻² (PEAK)

the measurement range (PEAK) with the measurement error < ± 0.5 dB:

from 0.02 ms⁻² to 1410 ms⁻².

| RANGE (RMS) | Range of measurements | |
|--------------------------------|------------------------------|--------------------------|
| 316 mms ⁻² (110 dB) | from 0.0005 ms ⁻² | to 1 ms ⁻² |
| 3.16 ms ⁻² (130 dB) | from 0.001 ms ⁻² | to 10 ms ⁻² |
| 31.6 ms ⁻² (150 dB) | from 0.01 ms ⁻² | to 100 ms ⁻² |
| 316 ms ⁻² (170 dB) | from 0.1 ms ⁻² | to 1000 ms ⁻² |

INPUT: Charge

the measurement ranges for the distance from noise > 5 dB:

from 0,001 ms⁻² to 1000 ms⁻² (the sinusoidal signal RMS)

from 0.002 ms⁻² to 1410 ms⁻² (PEAK)

the measurement range (PEAK) with the measurement error < ± 0.5 dB:

from 0.02 ms⁻² to 1410 ms⁻².

| RANGE (RMS) | Range of measurements | |
|--------------------------------|-----------------------------|--------------------------|
| 316 mms ⁻² (110 dB) | from 0.001 ms ⁻² | to 1 ms ⁻² |
| 3.16 ms ⁻² (130 dB) | from 0.001 ms ⁻² | to 10 ms ⁻² |
| 31.6 ms ⁻² (150 dB) | from 0.01 ms ⁻² | to 100 ms ⁻² |
| 316 ms ⁻² (170 dB) | from 0.1 ms ⁻² | to 1000 ms ⁻² |



Notice: In the measurement of the signal with the **crest factor $n > 1.41$** the **upper measurement range for the RMS value is reduced**. Its value can be calculated from the equation:

$A_n = A + 10 - 20 \log(n / \sqrt{2})$ [m], where **A** is the given range for the sinusoidal signal.

E.g. for **$n = 10$** and **$A = 130$** the value of **A_{10}** is equal to = **123 dB**.



Notice: In the measurement conditions with the strong electromagnetic disturbances (e.g. near the high-voltage transmission lines) the lower measurement limit can be drastically shifted as the result of the external field influence on the measurement cables. In such cases the careful shielding of the measurement cables is strongly recommended. It is worth to underline that the estimation of the external influence can be performed in-site in the **ANALYZER MODE** of the instrument by the observations of the measurement signal spectrum.

Frequency ranges for the acceleration measurement (for the transducer with the sensitivity equal to 10 mV/ms⁻² or 10 pC/ms⁻²):

| | |
|------------------------------|---|
| 0.2 Hz ÷ 200 Hz | in the vibration measurement influencing human body - W-Bxy , W-Bz , W-Bc and KB filters, |
| 0.8 Hz ÷ 1 kHz | in the vibration measurement influencing human body - H-A filter, |
| 5.0 Hz ÷ 11.93 kHz (-3 dB) | in the linear measurements with the Lin filter, |
| 0.625 Hz ÷ 11.93 kHz (-3 dB) | in the linear measurements with the HP filter. |



Notice: With the application of another vibration transducer the frequency range given above for the **HP** and **Lin** filter can be limited.

Range of the measurement results indication



Notice: The **OVERLOAD** warning (\emptyset) appears when the **Peak** value of the measured signal exceeds 13.2 dB the nominal value of the current range.



Notice: In the case when the measurement result is corrected by the calibration factor (**CALIBR.:On**) the **OVERLOAD** warning appears when the input signal exceeds the different level then mentioned above (e.g. if the scale factor is equal to +10 dB and the measurement range is equal to 150 dB the **OVERLOAD** warning will appear if the measured value surpasses ca 170.2 dB – for the RMS of the sinusoidal signal).



Notice: The **UNDERRANGE** warning (\downarrow) appears when the **RMS** value of the input signal is less then 60 dB in the relation to the nominal value of the current (active) range (it means ca 70 dB less then maximal level measured in the current range – for the sinusoidal signal).

Basic error for the displacement measurement:

< ± 0.7 dB.

Instrument's pre-heating time: 1 minute.

Measurement channel calibration:

vibrational: by the measurement of the standard signal generated by the external vibration calibrator,
digital: by the declaration of the transducer's sensitivity.

Measurements of the vibration's velocity

Measurement ranges for the velocity (for the transducer with the sensitivity equal to 10 mV/ms⁻² or 10 pC/ms⁻²):

9 ranges 0.003 m/s, 0.01 m/s, 0.03 m/s, 0.1 m/s, 0.3 m/s, 1 m/s, 3 m/s, 10 m/s and 30 m/s
(or 130 dB, 140 dB, 150 dB, 160 dB, 170 dB, 180 dB, 190 dB, 200 dB and 210 dB
in relation to 10⁻⁹ ms⁻¹).

Values of the measured velocity (for the transducer with the sensitivity equal to 10 mV/ms^{-2} or 10 pC/ms^{-2}):

- the **Vel1** filter, **INPUT: Accel.**

| RANGE (RMS) | Measurement range | |
|--------------------|---------------------------------------|--------------------------------------|
| | f = 1 Hz | f = 270 Hz |
| 31.6 mm/s (150 dB) | from 100 $\mu\text{m/s}$ to 0.126 m/s | from 100 $\mu\text{m/s}$ to 0.5 mm/s |
| 0.316 m/s (170 dB) | from 500 $\mu\text{m/s}$ to 1.26 m/s | from 500 $\mu\text{m/s}$ to 5 mm/s |
| 3.16 m/s (190 dB) | from 5 mm/s to 18.2 m/s | from 5 mm/s to 50 mm/s |
| 31.6 m/s (210 dB) | from 50 mm/s to 182 m/s | from 50 mm/s to 0.5 m/s |

- the **Vel1** filter, **INPUT: Charge**

| RANGE (RMS) | Measurement range | |
|--------------------|--------------------------------------|--------------------------------------|
| | f = 1 Hz | f = 330 Hz |
| 31.6 mm/s (150 dB) | from 100 $\mu\text{m/s}$ to 0.16 m/s | from 100 $\mu\text{m/s}$ to 0.5 mm/s |
| 0.316 m/s (170 dB) | from 500 $\mu\text{m/s}$ to 1.6 m/s | from 500 $\mu\text{m/s}$ to 5 mm/s |
| 3.16 m/s (190 dB) | from 5 mm/s to 16 m/s | from 5 mm/s to 50 mm/s |
| 31.6 m/s (210 dB) | from 50 mm/s to 160 m/s | from 50 mm/s to 0.5 m/s |

- the **Vel3** filter, **INPUT: Accel.**

| RANGE (RMS) | Measurement range | |
|-------------------|-------------------------------------|---|
| | f = 3 Hz | f = 850 Hz |
| 0.01 m/s (140 dB) | from 50 $\mu\text{m/s}$ to 4 mm/s | from 50 $\mu\text{m/s}$ to 0.16 $\mu\text{m/s}$ |
| 0.1 m/s (160 dB) | from 160 $\mu\text{m/s}$ to 0.4 m/s | from 160 $\mu\text{m/s}$ to 1.6 mm/s |
| 1 m/s (180 dB) | from 1.6 mm/s to 5.8 m/s | from 1.6 mm/s to 16 mm/s |
| 10 m/s (200 dB) | from 16 mm/s to 58 m/s | from 16 mm/s to 160 mm/s |

- the **Vel3** filter, **INPUT: Charge**

| RANGE (RMS) | Measurement range | |
|-------------------|-------------------------------------|---|
| | f = 3 Hz | f = 1000 Hz |
| 0.01 m/s (140 dB) | from 50 $\mu\text{m/s}$ to 5 mm/s | from 50 $\mu\text{m/s}$ to 0.16 $\mu\text{m/s}$ |
| 0.1 m/s (160 dB) | from 160 $\mu\text{m/s}$ to 0.5 m/s | from 160 $\mu\text{m/s}$ to 1.6 mm/s |
| 1 m/s (180 dB) | from 1.6 mm/s to 5 m/s | from 1.6 mm/s to 16 mm/s |
| 10 m/s (200 dB) | from 16 mm/s to 50 m/s | from 16 mm/s to 160 mm/s |

- the **Vel10** filter, **INPUT: Accel.**

| RANGE (RMS) | Measurement range | |
|--------------------|---------------------------|---------------------------|
| | f = 10 Hz | f = 2750 Hz |
| 3.16 mm/s (130 dB) | from 20 µm/s to 12.5 mm/s | from 20 µm/s to 0.05 mm/s |
| 31.6 mm/s (150 dB) | from 50 µm/s to 125 mm/s | from 50 µm/s to 0.5 mm/s |
| 0.316 m/s (170 dB) | from 0.5 mm/s to 1.55 m/s | from 0.5 mm/s to 5 mm/s |
| 3.16 m/s (190 dB) | from 5 mm/s to 15.5 m/s | from 5 mm/s to 50 mm/s |

- the **Vel10** filter, **INPUT: Charge**

| RANGE (RMS) | Measurement range | |
|--------------------|---------------------------|---------------------------|
| | f = 10 Hz | f = 3000 Hz |
| 3.16 mm/s (130 dB) | from 20 µm/s to 15.5 mm/s | from 20 µm/s to 0.05 mm/s |
| 31.6 mm/s (150 dB) | from 50 µm/s to 155 mm/s | from 50 µm/s to 0.5 mm/s |
| 0.316 m/s (170 dB) | from 0.5 mm/s to 1.55 m/s | from 0.5 mm/s to 5 mm/s |
| 3.16 m/s (190 dB) | from 5 mm/s to 15.5 m/s | from 5 mm/s to 50 mm/s |

- the **MF-Vel** filter, **INPUT: Accel.**

| RANGE (RMS) | Measurement range | |
|--------------------|---------------------------|---------------------------|
| | f = 10 Hz | f = 1000 Hz |
| 3.16 mm/s (130 dB) | from 20 µm/s to 12.5 mm/s | from 20 µm/s to 0.15 mm/s |
| 31.6 mm/s (150 dB) | from 50 µm/s to 125 mm/s | from 50 µm/s to 1.5 mm/s |
| 0.316 m/s (170 dB) | from 0,5 mm/s to 1.55 m/s | from 0.5 mm/s to 15 mm/s |
| 3.16 m/s (190 dB) | from 5 mm/s to 15.5 m/s | from 5 mm/s to 150 mm/s |

- the **MF-Vel** filter, **INPUT: Charge**

| RANGE (RMS) | Measurement range | |
|--------------------|---------------------------|---------------------------|
| | f = 10 Hz | f = 1000 Hz |
| 3.16 mm/s (130 dB) | from 20 µm/s to 15.5 mm/s | from 20 µm/s to 0.15 mm/s |
| 31.6 mm/s (150 dB) | from 50 µm/s to 155 mm/s | from 50 µm/s to 1.5 mm/s |
| 0.316 m/s (170 dB) | from 0.5 mm/s to 1.55 m/s | from 0.5 mm/s to 15 mm/s |
| 3.16 m/s (190 dB) | from 5 mm/s to 15.5 m/s | from 5 mm/s to 150 mm/s |



Notice: In the measurement of the signal with the **crest factor** $n > 1.41$ the **upper measurement range for the RMS value is reduced**. Its value can be calculated from the equation: $A_n = A + 10 - 20 \log(n / \sqrt{2})$ [m], where **A** is the given range for the sinusoidal signal. E.g. for $n = 10$ and $A = 170$ the value of A_{10} is equal to = **163 dB**.

Basic error for the displacement measurement:< $\pm 8\%$.**Instrument's pre-heating time:** 1 minute.**Measurement channel calibration:**

vibrational: by the measurement of the standard signal generated by the external vibration calibrator,
digital: by the declaration of the transducer's sensitivity.

Measurements of the vibration's displacement**Measurement ranges for the displacement** (for the transducer with the sensitivity equal to 10 mV/ms^{-2} or 10 pC/ms^{-2}):6 ranges 0.0001 m, 0.001 m, 0.01 m, 0.1 m, 1 m and 10 m (or 160 dB, 180 dB, 200 dB, 220 dB, 240 dB and 260 dB in the relation to 10^{-12} m).**Values of the measured displacement** (for the transducer with the sensitivity equal to 10 mV/ms^{-2} or 10 pC/ms^{-2}):

- the DiI1 filter, **INPUT: Accel.** or **INPUT: Charge**

| RANGE (RMS) | Measurement range | |
|-----------------|---------------------------------|---|
| | f = 1 Hz | f = 18 Hz |
| 0.01 m (200 dB) | from 20 μm to 25 mm | from 20 μm to 80 μm |
| 0.1 m (220 dB) | from 80 μm to 0.25 m | from 80 μm to 0.8 mm |
| 1 m (240 dB) | from 0,8 mm to 2.5 m | from 0.8 mm to 8 mm |
| 10 m (260 dB) | from 80 mm to 25 m | from 80 mm to 80 m |

- the DiI3 filter, **INPUT: Accel.** or **INPUT: Charge**

| RANGE (RMS) | Measurement range | |
|------------------|---------------------------------|--|
| | f = 3 Hz | f = 57 Hz |
| 0.001 m (180 dB) | from 3 μm to 2.7 mm | from 3 μm to 8 μm |
| 0.01 m (200 dB) | from 8 μm to 27 mm | from 8 μm to 80 μm |
| 0.1 m (220 dB) | from 80 μm to 0.27 m | from 80 μm to 0.8 mm |
| 1 m (240 dB) | from 0.8 mm to 2.7 m | from 0.8 mm to 8 mm |

- the **Dil10** filter, **INPUT: Accel.** or **INPUT: Charge**

| RANGE (RMS) | Measurement range | |
|-------------------|------------------------|-----------------------|
| | f = 10 Hz | f = 181 Hz |
| 0.0001 m (160 dB) | from 0.2 μm to 0.24 mm | from 0.2 μm to 0.8 μm |
| 0.001 m (180 dB) | from 0.8 μm to 24 mm | from 0.8 μm to 8 μm |
| 0.01 m (200 dB) | from 8 μm to 0.24 m | from 8 μm to 80 μm |
| 0.1 m (220 dB) | from 80 μm to 2.4 m | from 80 μm to 0.8 mm |



Notice: In the measurement of the signal with the **crest factor $n > 1.41$** the upper measurement range for the RMS value is reduced. Its value can be calculated from the equation:

$A_n = A + 10 - 20 \log(n / \sqrt{2})$ [m], where **A** is the given range for the sinusoidal signal.

E.g. for $n = 10$ and $A = 220$ the value of A_{10} is equal to = **213 dB**.

Basic error for the displacement measurement:

< ± 8 %.

Instrument's pre-heating time: 1 minute.

Measurement channel calibration:

vibrational: by the measurement of the standard signal generated by the external vibration calibrator,

digital: by the declaration of the transducer's sensitivity.

E9. System for vibration measurements with the SV 08A module

System conforms to the ISO 8041 standard for the general vibration measurements and for human response to the mechanical vibration meeting requirements for Type 1 Meter.

System configuration:

- Handheld sound & vibration analyser SVAN 912AE
- The SV 08A module
- Measurement IEPE transducer with the sensitivity from 0.01 mV/ms⁻² to 1500 mV/ms⁻².

Measurements of the vibration's acceleration

Measurement ranges for the acceleration (for the transducer with the sensitivity equal to 10 mV/ms⁻²):

4 ranges with the nominal values: 316 mms⁻², 3.16 ms⁻², 31.6 ms⁻², 316 ms⁻²
(110 dB, 130 dB, 150 dB, 170 dB related to 10⁻⁶ ms⁻²).

Values of the measured acceleration (for the transducer with the sensitivity equal to 10 mV/ms⁻²):

- linear measurement (with the **HP** or **Lin** filter) **INPUT: Accel.**

the measurement ranges for the distance from noise > 5 dB:
from 0.002 ms⁻² to 1000 ms⁻² (the sinusoidal signal RMS)
from 0.01 ms⁻² to 1410 ms⁻² (PEAK)

the measurement range (PEAK) with the measurement error < ± 0.5 dB:
from 0.1 ms⁻² to 1410 ms⁻².

| RANGE (RMS) | Range of measurements | |
|--------------------------------|-----------------------------|--------------------------|
| 316 mms ⁻² (110 dB) | from 0.002 ms ⁻² | to 1 ms ⁻² |
| 3.16 ms ⁻² (130 dB) | from 3.16 mms ⁻² | to 10 ms ⁻² |
| 31.6 ms ⁻² (150 dB) | from 31.6 mms ⁻² | to 100 ms ⁻² |
| 316 ms ⁻² (170 dB) | from 316 mms ⁻² | to 1000 ms ⁻² |

- corrected measurement (with the **W-Bxy**, **W-Bz**, **W-Bc**, **H-A** or **KB** filter) **INPUT: Accel.**

the measurement ranges for the distance from noise > 5 dB:
from 316 μms⁻² to 1000 ms⁻² (the sinusoidal signal RMS)
from 0.001 ms⁻² to 1410 ms⁻² (PEAK)

the measurement range (PEAK) with the measurement error < ± 0.5 dB:
from 0.01 ms⁻² to 1410 ms⁻².

| RANGE (RMS) | Range of measurements | |
|--------------------------------|-----------------------------|--------------------------|
| 316 mms ⁻² (110 dB) | from 316 μms ⁻² | to 1 ms ⁻² |
| 3.16 ms ⁻² (130 dB) | from 3.16 mms ⁻² | to 10 ms ⁻² |
| 31.6 ms ⁻² (150 dB) | from 31.6 mms ⁻² | to 100 ms ⁻² |
| 316 ms ⁻² (170 dB) | from 316 mms ⁻² | to 1000 ms ⁻² |



Notice: In the measurement of the signal with the **crest factor** $n > 1.41$ the **upper measurement range for the RMS value is reduced**. Its value can be calculated from the equation: $A_n = A + 10 - 20 \log(n / \sqrt{2})$ [m], where **A** is the given range for the sinusoidal signal. E.g. for $n = 10$ and $A = 130$ the value of A_{10} is equal to = **123 dB**.



Notice: In the measurement conditions with the strong electromagnetic disturbances (e.g. near the high-voltage transmission lines) the lower measurement limit can be drastically shifted as the result of the external field influence on the measurement cables. In such cases the careful shielding of the measurement cables is strongly recommended. It is worth to underline that the estimation of the external influence can be performed in-site in the **ANALYZER MODE** of the instrument by the observations of the measurement signal spectrum.

Frequency ranges for the acceleration measurement (for the transducer with the sensitivity equal to 10 mV/ms²):

| | |
|------------------------------|---|
| 0.2 Hz ÷ 200 Hz | in the vibration measurement influencing human body - W-Bxy , W-Bz , W-Bc and KB filters, |
| 0.8 Hz ÷ 1 kHz | in the vibration measurement influencing human body - H-A filter, |
| 5.0 Hz ÷ 11.93 kHz (-3 dB) | in the linear measurements with the Lin filter, |
| 0.625 Hz ÷ 11.93 kHz (-3 dB) | in the linear measurements with the HP filter. |



Notice: With the application of another vibration transducer the frequency range given above for the **HP** and **Lin** filter can be limited.

Range of the measurement results indication



Notice: The **OVERLOAD** warning (\emptyset) appears when the **Peak** value of the measured signal exceeds 13.2 dB the nominal value of the current range.



Notice: In the case when the measurement result is corrected by the calibration factor (**CALIBR.:On**) the **OVERLOAD** warning appears when the input signal exceeds the different level then mentioned above (e.g. if the scale factor is equal to +10 dB and the measurement range is equal to 150 dB the **OVERLOAD** warning will appear if the measured value surpasses ca 170.2 dB – for the RMS of the sinusoidal signal).



Notice: The **UNDERRANGE** warning (\downarrow) appears when the **RMS** value of the input signal is less than 60 dB in the relation to the nominal value of the current (active) range (it means ca 70 dB less than maximal level measured in the current range – for the sinusoidal signal).

Basic error for the displacement measurement:

<math>\pm 0.7 \text{ dB}</math>.

Instrument's pre-heating time: 1 minute.**Measurement channel calibration:**

vibrational: by the measurement of the standard signal generated by the external vibration calibrator,

digital: by the declaration of the transducer's sensitivity.

Measurements of the vibration's velocity**Measurement ranges for the velocity** (for the transducer with the sensitivity equal to 10 mV/ms^2):9 ranges 0.003 m/s, 0.01 m/s, 0.03 m/s, 0.1 m/s, 0.3 m/s, 1 m/s, 3 m/s, 10 m/s and 30 m/s
(or 130 dB, 140 dB, 150 dB, 160 dB, 170 dB, 180 dB, 190 dB, 200 dB and 210 dB
in relation to 10^{-9} ms^{-1}).**Values of the measured velocity** (for the transducer with the sensitivity equal to 10 mV/ms^2):

- the Vel1 filter, INPUT: Accel.

| RANGE (RMS) | Measurement range | |
|--------------------|---------------------------------------|--------------------------------------|
| | f = 1 Hz | f = 330 Hz |
| 31.6 mm/s (150 dB) | from 100 $\mu\text{m/s}$ to 0.158 m/s | from 100 $\mu\text{m/s}$ to 0.5 mm/s |
| 0.316 m/s (170 dB) | from 500 $\mu\text{m/s}$ to 1.58 m/s | from 500 $\mu\text{m/s}$ to 5 mm/s |
| 3.16 m/s (190 dB) | from 5 mm/s to 15.8 m/s | from 5 mm/s to 50 mm/s |
| 31.6 m/s (210 dB) | from 50 mm/s to 158 m/s | from 50 mm/s to 0.5 m/s |

- the Vel3 filter, INPUT: Accel.

| RANGE (RMS) | Measurement range | |
|-------------------|--------------------------------------|---|
| | f = 3 Hz | f = 1000 Hz |
| 0.01 m/s (140 dB) | from 50 $\mu\text{m/s}$ to 48 mm/s | from 50 $\mu\text{m/s}$ to 0.16 $\mu\text{m/s}$ |
| 0.1 m/s (160 dB) | from 160 $\mu\text{m/s}$ to 0.48 m/s | from 160 $\mu\text{m/s}$ to 1.6 mm/s |
| 1 m/s (180 dB) | from 1.6 mm/s to 4.8 m/s | from 1.6 mm/s to 16 mm/s |
| 10 m/s (200 dB) | from 16 mm/s to 48 m/s | from 16 mm/s to 160 mm/s |

- the Vel10 filter, INPUT: Accel.

| RANGE (RMS) | Measurement range | |
|--------------------|--------------------------------------|--------------------------------------|
| | f = 10 Hz | f = 3000 Hz |
| 3.16 mm/s (130 dB) | from 20 $\mu\text{m/s}$ to 15.5 mm/s | from 20 $\mu\text{m/s}$ to 0.05 mm/s |
| 31.6 mm/s (150 dB) | from 50 $\mu\text{m/s}$ to 155 mm/s | from 50 $\mu\text{m/s}$ to 0.5 mm/s |
| 0.316 m/s (170 dB) | from 0.5 mm/s to 1.55 m/s | from 0.5 mm/s to 5 mm/s |
| 3.1 m/s (190 dB) | from 5 mm/s to 15.5 m/s | from 5 mm/s to 50 mm/s |

- the MF-Vel filter, INPUT: Accel.

| RANGE (RMS) | Measurement range | |
|--------------------|---------------------------|---------------------------|
| | f = 10 Hz | f = 1000 Hz |
| 3.16 mm/s (130 dB) | from 20 µm/s to 15.5 mm/s | from 20 µm/s to 0.15 mm/s |
| 31.6 mm/s (150 dB) | from 50 µm/s to 155 mm/s | from 50 µm/s to 1.5 mm/s |
| 0.316 m/s (170 dB) | from 0.5 mm/s to 1.55 m/s | from 0.5 mm/s to 15 mm/s |
| 3.1 m/s (190 dB) | from 5 mm/s to 15.5 m/s | from 5 mm/s to 150 mm/s |



Notice: In the measurement of the signal with the **crest factor $n > 1.41$** the upper measurement range for the RMS value is reduced. Its value can be calculated from the equation: $A_n = A + 10 - 20 \log(n / \sqrt{2})$ [dB], where **A** is the given range for the sinusoidal signal. E.g. for $n = 10$ and $A = 170$ the value of A_{10} is equal to = **163 dB**.

Basic error for the velocity measurement:

< ± 8%.

Instrument's pre-heating time: 1 minute.

Measurement channel calibration:

vibrational: by the measurement of the standard signal generated by the external vibration calibrator,
digital: by the declaration of the transducer's sensitivity.

Measurements of the vibration's displacement

Measurement ranges for the displacement (for the transducer with the sensitivity equal to 10 mV/ms⁻²):

6 ranges 0.0001 m, 0.001 m, 0.01 m, 0.1 m, 1 m and 10 m (or 160 dB, 180 dB, 200 dB, 220 dB, 240 dB and 260 dB in the relation to 10⁻¹² m).

Values of the measured displacement (for the transducer with the sensitivity equal to 10 mV/ms⁻²):

- the Dil1 filter, INPUT: Accel.

| RANGE (RMS) | Measurement range | |
|-----------------|----------------------|----------------------|
| | f = 1 Hz | f = 18 Hz |
| 0.01 m (200 dB) | from 20 µm to 25 mm | from 20 µm to 80 µm |
| 0.1 m (220 dB) | from 80 µm to 0.25 m | from 80 µm to 0.8 mm |
| 1 m (240 dB) | from 0.8 mm to 2.5 m | from 0.8 mm to 8 mm |
| 10 m (260 dB) | from 80 mm to 25 m | from 80 mm to 80 m |

- the DiI3 filter, INPUT: Accel.

| RANGE (RMS) | Measurement range | |
|------------------|----------------------|----------------------|
| | f = 3 Hz | f = 57 Hz |
| 0.001 m (180 dB) | from 3 μm to 2.7 mm | from 3 μm to 8 μm |
| 0.01 m (200 dB) | from 8 μm to 27 mm | from 8 μm to 80 μm |
| 0.1 m (220 dB) | from 80 μm to 0.27 m | from 80 μm to 0.8 mm |
| 1 m (240 dB) | from 0.8 mm to 2.7 m | from 0.8 mm to 8 mm |

- the DiI10 filter, INPUT: Accel.

| RANGE (RMS) | Measurement range | |
|-------------------|------------------------|-----------------------|
| | f = 10 Hz | f = 181 Hz |
| 0.0001 m (160 dB) | from 0.2 μm to 0.24 mm | from 0.2 μm to 0.8 μm |
| 0.001 m (180 dB) | from 0.8 μm to 24 mm | from 0.8 μm to 8 μm |
| 0.01 m (200 dB) | from 8 μm to 0.24 m | from 8 μm to 80 μm |
| 0.1 m (220 dB) | from 80 μm to 2.4 m | from 80 μm to 0.8 mm |



Notice: In the measurement of the signal with the **crest factor $n > 1.41$** the upper measurement range for the RMS value is reduced. Its value can be calculated from the equation: $A_n = A + 10 - 20 \log(n / \sqrt{2})$ [m], where **A** is the given range for the sinusoidal signal. E.g. for **n = 10** and **A = 220** the value of **A₁₀** is equal to = **213 dB**.

Basic error for the displacement measurement:

< ± 8%.

Instrument's pre-heating time: 1 minute.

Measurement channel calibration:

vibrational: by the measurement of the standard signal generated by the external vibration calibrator,

digital: by the declaration of the transducer's sensitivity.